

SOME SIGNIFICANT DEVELOPMENTS IN AERODYNAMICS SINCE 1946

DANIEL and FLORENCE GUGGENHEIM MEMORIAL LECTURE

Madrid, September 1958

IT IS a great honor and pleasure for me to give the first Daniel and Florence Guggenheim Memorial Lecture before this distinguished international gathering. The name Guggenheim will be connected for ever in the history of aviation with the development of the aeronautical sciences. In fact, the Daniel Guggenheim Fund for the Promotion of Aeronautics which Daniel Guggenheim established in 1926 gave a great impetus to education and research at a number of American universities. I am personally indebted to the Guggenheim family by the fact that my change of continents from Europe to America originated with Daniel Guggenheim and Robert A. Millikan, world famous physicist and then head of the California Institute of Technology. The story, as I learned it from R. A. Millikan, was that in 1926, as the Daniel Guggenheim Fund started to distribute grants to several colleges for the purpose of forming graduate schools for aeronautics, Millikan undertook a trip to Long Island where Mr. Guggenheim lived. During his visit with Mr. Guggenheim, Millikan told him that he would make the greatest mistake of his life if a sizeable chunk of the money of the Fund did not go to California. California will be, Millikan insisted, in the near future, the most important center of American aircraft production, due to climatic conditions and availability of space for flying establishments. Mr. Guggenheim answered that he would provide the funds for a graduate school if Millikan would bring to Pasadena somebody from Europe who is familiar with and is active in aeronautical research, and especially familiar with the theoretical side of research. In this way I received a call to come to the United States. I was told later that Robert A. Millikan said: "First I aimed at Prandtl—then I settled on Kármán." Prandtl was—without doubt—the leading genius in the early development of modern aerodynamics.

Daniel Guggenheim was a man of great vision, with a lively interest in the progress of aeronautics. I remember that after I went through the United States, visiting all the places where Guggenheim funds were invested for the promotion of aeronautical science, he asked me what he should do, in addition to supporting the schools, so that aeronautical science would flourish in the United States as it had grown and brought ripe fruits in several European countries during the first two decades of our century. I suggested that it would be extremely desirable to have a

kind of Handbook of Aerodynamic Theory which would lay down the present state of fundamental aeronautical knowledge, so that young American scholars would know from which point to start. Then I said jokingly, "In Europe it was very helpful that young scientists could meet in nice and quiet 'cafés' for informal discussions. Unfortunately there is no equivalent institution in the United States." Mr. Guggenheim answered: "All right, I shall provide the money for the book." (As a matter of fact, this was the origin of Durand's *Aerodynamic Theory*, a collective work based on international authorship which has had a great influence on the development of American scientific literature in the field of Aerodynamics.) "However," he continued, "I will not go into the cafeteria business—even for science's sake."

Daniel Guggenheim, born in Philadelphia in 1856, was of the second generation in the leadership of the large Guggenheim enterprises in mining and affiliated industries. His son, our great friend Harry, once told me jokingly that, at the time of his grandfather a really good man—in order to be recognized as such—had to create a great fortune. When his father was in business, the main duty was to broaden the scope and to maintain the level of his enterprises. "Of me," he said, "they only expect that I spend the money usefully and gracefully".

I am sure that this formulation of Harry F. Guggenheim's activities is extremely modest. He has an impressive record of public service; he was a successful Ambassador of the United States to Cuba. There is no doubt that his interests in aeronautics and his personal experience in aviation, especially as a naval aviator during the First World War, were the decisive factor for Daniel Guggenheim's donations being directed towards the promotion of the Aeronautical Sciences. Also, the organization of the Safe Aircraft Competition in 1930, the active support of Professor Goddard's early efforts in rocket research, the establishment of the Daniel and Florence Guggenheim Jet Propulsion Centers at CALTECH and Princeton University, the Institute of Flight Structures at Columbia University and the Center for Aviation Health and Safety at Harvard are far beyond the qualification "spend the money usefully and gracefully". They are proofs of an extraordinary vision for the kind of education and research needed for the progress of aviation. And last, but not least, this "First International Congress for the Aeronautical Sciences" owes its birth not only to the donation of funds by the Daniel and Florence Guggenheim Foundation, but in the first place to the initiative and desire of Harry F. Guggenheim to spend the money for the organization of an international congress open to scientists and engineers of all the nations of the globe that have an association or group devoted to the aeronautical sciences.

I think I shall now proceed to the technical part of my lecture.

For my review of progress in aerodynamics, I would like to choose as a point of departure my Wright Brothers lecture delivered on the 17th of December, 1946. I wrote at that time:

"I believe we have now arrived at the stage where knowledge of supersonic aerodynamics should be considered by the aeronautical engineer as a necessary prerequisite of his art. This branch of aerodynamics should cease to be a collection of mathematical and half-digested, isolated, experimental results. The aeronautical engineer should start to get the same feeling for the facts of supersonic flight as he acquired in the domain of subsonic velocities by a long process of theoretical study, experimental research, and flight experience."

I have the impression that this goal has generally been achieved. Due to the rapid progress in the theory of supersonic wings, bodies and wing-body combinations exposed to supersonic flow as published in the scientific literature; due to the experimental work carried out in newly-created facilities in governmental and industrial laboratories; and finally due to the improved training of advanced students at our aeronautical schools, a number of engineering firms have at their disposal large staffs with the necessary grasp and appreciation of the main features of supersonic aerodynamics. As a matter of fact, some of our supersonic bombers have been designed on the basis of more detailed aerodynamic calculations than was possible in the case of the best subsonic aircraft.

However, the honeymoon was short. Pretty soon quite new problems were facing the aeronautical engineer, who nowadays is pleased to call himself a missile engineer, or even a space technologist.

The problem of ballistic missiles led us to the range of hypersonic speeds, to speeds which are not only comparable with sound velocity but are of a definitely higher order than the velocity of sound. At first sight, the hypersonic range introduces certain simplifications into the flow problem; as a matter of fact it was pointed out as early as 1931 by P. S. Epstein, in a paper devoted to the problem of the drag of artillery projectiles, that for very large Mach numbers the classical Newtonian law of air resistance becomes valid. At that time, and also at the time of the memorable Volta Congress for high speed, held at Rome, Italy, in 1935, high Mach numbers belonged to the realm of academic speculation.

The simplification introduced by very high Mach numbers is largely overbalanced by the complications due to the high temperatures caused by shock and friction. The production of heat, an annoyance in flight at moderate Mach numbers, becomes a major problem at hypersonic speeds. Furthermore, and as a new complication, one has to take into account the chemical changes in the air, such as dissociation and recombination. No longer are we dealing with pure aerodynamics, nor aerothermodynamics; fluid mechanics must now be combined not only with thermodynamics, but also with chemistry.

I suggested the term *aerothermochemistry* for the combination of these three disciplines. I had mainly in mind problems related to combustion, like the flame theory, the theory of quenching, and the like. Hypersonics

made it necessary to consider chemical reactions which occur without having been planned by the chemical engineer.

Recently, another combination of various disciplines has attracted considerable attention: fluid mechanics and the theory of the electromagnetic field. Some aspects of the motion of conducting liquids acted upon by electromagnetic forces were investigated several decades ago. I also remember that Albert Einstein gave some thought to a thoroughly practical problem in this field; he proposed the design of a refrigerator in which the coolant, for example a liquid metal, would be kept in circulation by an imposed electromagnetic field. He wanted to avoid the use of machinery which needs lubrication. However, the main interest for "magnetofluidmechanics" arose from celestial problems, such as the structure and the motions of galaxies, wave motions and turbulence in cosmic systems, and the like. Questions of space flight and problems related to the possible utilization of thermonuclear reactions led to an increasing interest in "plasmadynamics." I believe that a systematic nomenclature and classification of these new branches of combined fluidmechanics, electromagnetic theory and thermodynamics is yet lacking. Nevertheless, I believe that in a review of advances of aerodynamics they should at least be mentioned.

A detailed list of references is appended hereto. I want now to restrict myself to making some comments on some accomplishments in aerodynamics which—I believe—are most significant. I am aware that some of them will also be treated in a most competent way in the general lectures of my friends, Robert T. Jones and Antonio Ferri.

One general remark may precede. It is remarkable how far one can go with the so-called linear theory of supersonic flow, and how many useful conclusions for aircraft design can be derived from this simplified theory which, after all, is nothing else than "acoustics", i.e. it is based on the assumption that the flow is composed of a uniform parallel flow and a perturbation flow of small magnitude.

WING THEORY

Concerning wing theory, A. Puckett, in a paper published in 1946, applied the method of singularities which I had introduced, jointly with N. Moore, into the first theory of supersonic flow around axisymmetric bodies. We used supersonic sources distributed along the axis of the body. H. S. Tsien introduced doublets (bipoles) in order to include in the theory the lift for the case of a body of revolution with angle of attack. These supersonic sources and doublets are arranged in such a way that their effect is restricted to the interior of a Mach cone, the apex of which is the point of singularity. Thus the solution is essentially identical with the solution of a time-dependent two-dimensional acoustic problem, where the length-co-ordinate in the flow direction replaces the time-co-ordinate of the acoustic phenomena.

Subsonic wings are mostly calculated by means of the concept of the lifting line. Only in a few cases did it prove possible to solve the problem of the lifting surface. However, for the supersonic case the situation is more favorable. Especially if both the leading and trailing edges are of the supersonic type, i.e. if the components of the flight speed normal to the edges are greater than sound velocity, the local slope of the wing determines directly the distribution of sources over the wing plan form. These singularities, together with the condition that in undisturbed flow the pressure is equal to the ambient pressure, completely determine the disturbance potential.

Two complications occur if portions of the perimeter of the wing plan form are edges of the subsonic type:

For the case of a subsonic leading edge, the flow on the upper and the lower surfaces near the edge are no longer independent. The fluid flows around the edge with subsonic velocity, and one obtains a leading edge suction which has to be calculated. Furthermore, in the sector enclosed between leading edge and limiting Mach line, the pressure resulting from the upper and lower half spaces must be balanced.

In the case of a subsonic trailing edge the Kutta-Joukowski condition has to be satisfied; in other words, the velocity components normal to the edge on the upper and the lower surface must be equalized. This makes it necessary to compute and compensate the velocities induced by the trailing vortices in certain sectors of the plan form.

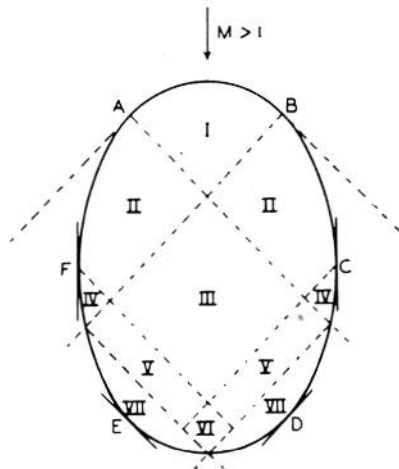

FIG. 1. Plan form of elliptic supersonic wing

Figure 1 is reproduced from an excellent review of the supersonic wing theory published by R. T. Jones and Doris Cohen in Vol. VII of the Princeton series *High Speed Aerodynamics and Jet Propulsion*. The figure shows for the case of an elliptic plan form the various domains which have to be treated in different ways. Sector I has a supersonic leading

edge, and is not influenced by any other portion of the wing plan form. Hence the Puckett method can be directly applied. Sector II has subsonic leading edges; Sectors IV, V, VI, VII are evidently influenced by the trailing vortices leaving the subsonic trailing edges FE and CD.

The vortex wake can be built up by super-position of horseshoe vortices (Fig. 2).

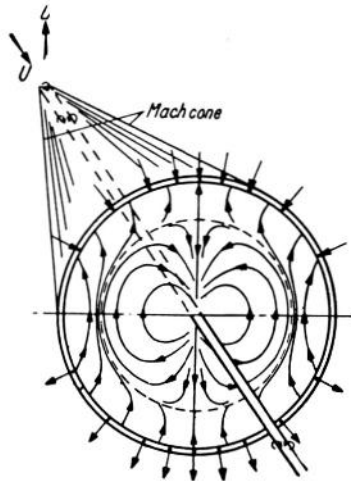

FIG. 2. Horseshoe vortex in supersonic flow

The problem of the subsonic leading edge was resolved in an ingenious way by a method apparently independently proposed by J. C. Evvard in the U.S.A. and E. A. Krasilshchikova in the U.S.S.R.

Before that, H. J. Stewart treated the special case of the delta wing with subsonic straight leading edges by means of the method of conical flows. This method, originally suggested by A. Busemann, became one of the most powerful methods of supersonic aerodynamics. It reduces the problem of three-dimensional flow to a two-dimensional problem which can be solved by means of Laplace's equation.

For example M. Roy of France and MacAdams and others of the U.S.A. treated the case of delta wings with flow separation at the apex as an example of conical flow.

The linearized wing theory made it possible for R. T. Jones to arrive at a series of important results concerning the minimum drag of supersonic wings. He made a very ingenious use of the concepts of the reverse flow and the combined flow. I believe, but I do not know for sure, that the concept of reversing the flow direction was mentioned for the first time in my Wright Brothers lecture quoted above. I found that the drag of a thin wing due to thickness remains unchanged if we reverse the flight direction. If we superpose both perturbances which correspond to the two opposite flight directions on one parallel uniform flow we arrive at a so-called combined flow. Using this concept and the independence of the

drag of the flight direction, R. T. Jones has shown that the drag of a symmetric flat wing of given plan form reaches a minimum if the thickness is distributed over the plan form in such a way that the drag per unit volume is equal for every wing element.

R. T. Jones also investigated the condition for the minimum of the drag caused by lift. He found that the optimum lift distribution over a given plan form is such that the downwash is constant over the plan form. It is evident that this result is a kind of generalization of Munk's rule for

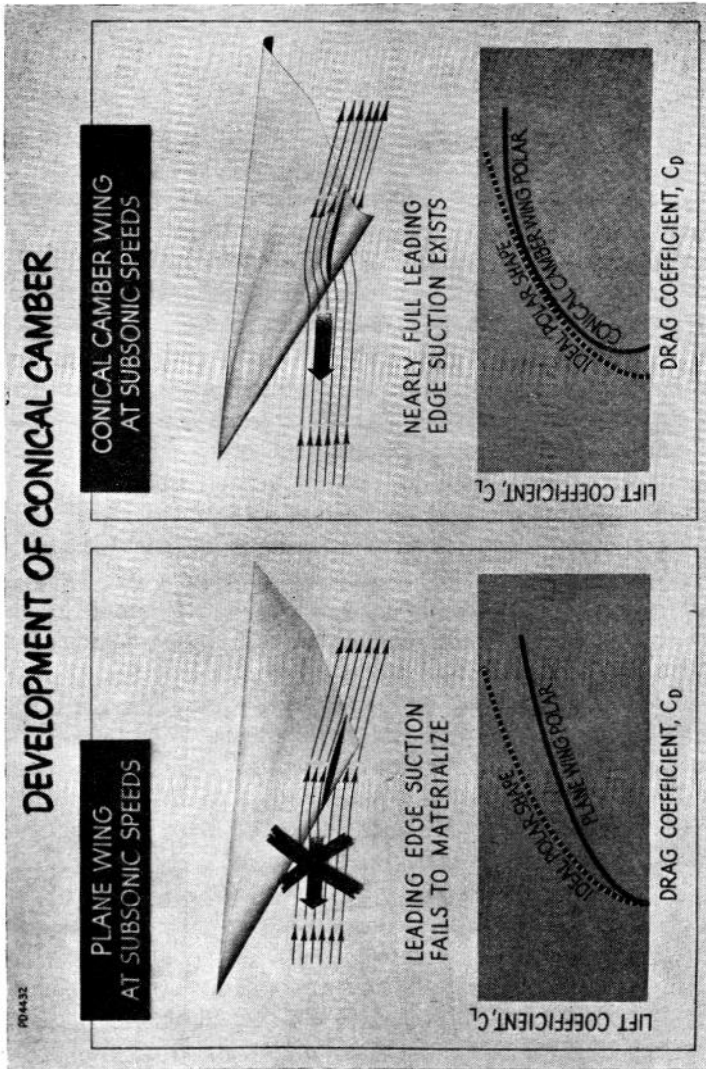

FIG. 3. Development of conical camber.

the optimum distribution of lift along a lifting line, which leads to the elliptical distribution in the classical subsonic wing theory.

Many special cases have been investigated from the viewpoint of minimizing drag. Thus, Doris Cohen has shown that for triangular wings with subsonic edges the minimum drag due to lift is obtained by using negative span-wise camber over most of the plan form. It is interesting that this idea was used in the design of the wing of the CONVAIR B-58 bomber (also called the HUSTLER). This development is attributed to C. F. Hall (Ames Laboratory). It is seen from the experimental results represented on Fig. 3 that the "conical camber" produces leading edge suction and thus essentially reduces drag.

SLENDER WINGS AND AIRCRAFT

With the increase of the speed of flight, aircraft in general became more and more slender; large-aspect ratios disappeared, and present-day aircraft mostly consist of long bodies and wings of small-aspect ratios. For such cases the application of the linearized theory had to be revised. Considerable confusion had been caused by formal application of the Prandtl-Glauert rules for compressibility effects to bodies of revolution and slender wings and bodies in general. This question was clarified by Goethert, Lighthill, Broderick, Ward and others in a satisfactory way. It was shown that the similarity theory of compressible flow, which was correct for wings of large-aspect ratio, gives completely false results for slender bodies. It was also shown that the computation of the pressure based on the axial component of the disturbance velocity is inexact, since, for example in the case of axisymmetric bodies, the influence of the radial velocity is often much larger. Hence it became necessary to describe the flow by the appropriate singularities, and to compute the pressure including the quadratic terms of the disturbance velocities. In order to simulate the flow around bodies which are neither thin wings nor axisymmetric bodies, multipoles have to be introduced.

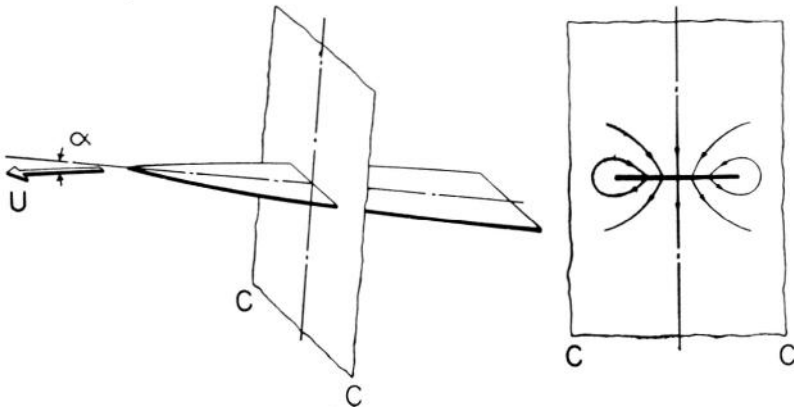

FIG. 4. Wing of low-aspect ratio.

A great simplification was achieved by extension of Munk's classical airship theory to slender bodies in general, both for subsonic or supersonic speeds, by R. T. Jones. This theory assumes that the flow around a slender body (wing or aircraft) can be considered as a super-position of a parallel uniform flow and a sequence of two-dimensional flows in planes perpendicular to the flight direction, as shown in Fig. 4. To some extent this is the opposite of Prandtl's classical assumption for his wing theory. As a matter of fact, for wings of large-aspect ratios, it was assumed that the flow in planes perpendicular to the wing axis can be identified with a two-dimensional flow with circulation around the wing section.

The slender body theory in general gives a better approximation to the pressure, forces and moments acting on the system than the pure linearized theory.

INTERFERENCE EFFECTS

We shall now consider interference effects between the wing and the body structures of the airplane which are necessary to carry payload, passengers or fuel. The most significant example of favorable interference is the arrangement popularly known as the *area rule*. W. Hayes has shown in his doctoral dissertation at the California Institute of Technology that the resulting flow around a system consisting of long bodies and a low-aspect ratio wing, at large distances, can be represented as originating from singularities distributed along the axis. Hence the drag can be considered as caused by a single equivalent body of revolution. Now we know—for example, according to the theories of W. Haack and W. R. Sears—the shape of the most favorable bodies of revolution as far as minimum drag is concerned. Thus the components of the aircraft can be arranged so that—at least for a given Mach number—the equivalent body of revolution approaches the shape corresponding to minimum drag. This leads for example to the conclusion that, in the case of nacelles arranged near the fuselage, the additional drag of the nacelles can be compensated by a reduction of the diameter of the fuselage in the appropriate section. We obtain in this way the shape of the fuselage known popularly as the “Marilyn Monroe body”. The name “area rule” originates from the fact that, for a flow near Mach 1, the section of the equivalent body of revolution is simply equal to the sum of the areas cut out by a plane laid through the section considered. The agreement of these theoretical ideas with drag measurements was shown by Whitcomb.

Another class of interference phenomena makes it possible to create favorable interference by reflection of compression and expansion waves on components of a lifting system.

The oldest example for such a procedure is the so-called Busemann biplane (Fig. 5). In this case we may transfer pressure from one wing to the rear portion of the other wing (for example from \overline{AB} to \overline{EF} and from \overline{DE} to \overline{BC}), so that the pressures acting on the forward and rear portions

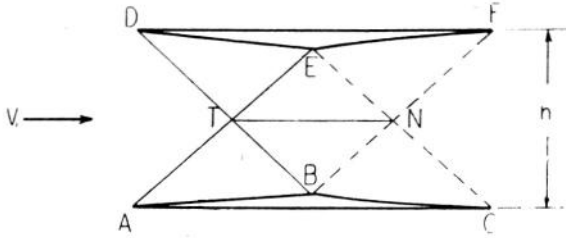

FIG. 5. Busemann biplane.

of the inner surface are balanced. Thus the drag due to thickness effect can be eliminated and we gain volume without additional drag.

An interesting example of similar favorable interference effects is represented by a combination of a horizontal delta wing and a vertical surface of wedge shape arranged below the wing parallel to the flight direction

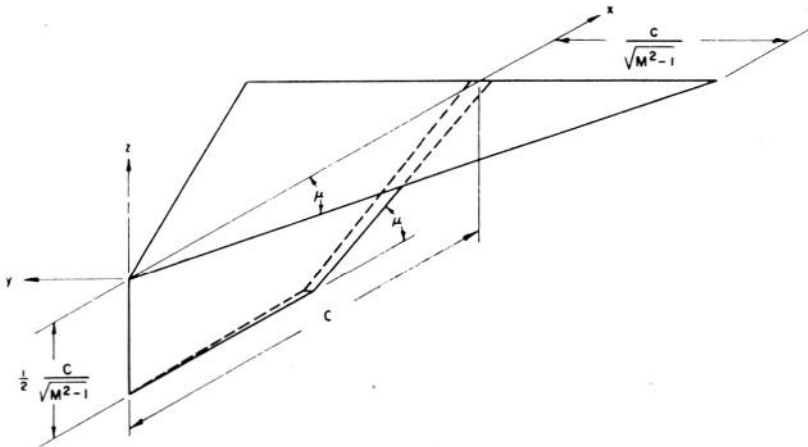

FIG. 6. Wedge-wing lifting configuration.

(Fig. 6). One can transfer the pressure created on the surface of the vertical wedge to the lower surface of the wing. Thus the total lift is increased, and one can show that the resulting lift/drag ratio is more favorable than for the case of a simple horizontal wing, which would furnish the same lift.

AEROELASTIC THEORIES

Concerning aeroelastic problems like flutter at high flying speeds, we have to mention the so-called "piston theory" initiated by M. J. Lighthill and worked out by H. Ashley and others. This theory assumes that the magnitude of the reaction of a high-speed flow on a wing surface can be approximated at every instant by considering the one-dimensional motion of an air column under the action of a moving piston. It seems that for Mach numbers superior to $M = 1.5$ this approximate theory furnishes usable results and greatly simplifies the computations.

NON-LINEAR THEORIES—HIGHER-ORDER
APPROXIMATIONS

It is not possible to enter into exact discussion of the highly intricate mathematical problems connected with the development of higher-order approximations for a solution of the equations of supersonic flow, even for the cases of plane and axisymmetric motions. However, the main trends of the pertinent approaches shall be indicated.

For the purpose of a two-dimensional airfoil theory Ackeret's fundamental and simple results correspond to a linearized theory. At a relatively early date (1935), Busemann showed the possibility of obtaining a correction of second order in the perturbation velocities, and in 1948 K. Friedrichs provided a means for obtaining shock shapes to the same degree of approximation. Therefore, a rather complete and accurate theoretical treatment of the two-dimensional airfoil problem is available. This applies as long as the effects of entropy changes are relatively unimportant. For practical airfoil shapes the condition seems to be satisfied up to Mach numbers of 5 or 6. Above this limit, temperature and real gas effects make the application of ideal gas laws illusory anyway.

The attempts to develop higher approximations for three-dimensional flows, at least for specific cases, are reviewed by M. J. Lighthill in his article "Higher Approximations" published in Section E, Vol. VI, of the Princeton series.

In the linearized theory simplifications are introduced into three aspects of the problem: first, the equation of motion is correct only approximately; second, the boundary conditions at the body are simplified; third, the pressure is computed on the basis of a simplified relation between pressure and velocity components. The simplest idea is to keep the linearized character of the equation of motion, but correct the boundary conditions and the pressure-velocity relations. One is tempted to call such theories "hybrid" theories. In general, the procedure leads to results which are in better agreement with exact solutions and/or the experimental evidence, but it can work also in the opposite sense.

J. B. Broderick and M. D. Van Dyke worked out second-order solutions on the basis of this general idea; Van Dyke uses the first-order linearized solutions as a starting point, whereas Broderick starts out from the slender body solution.

One of the main weaknesses of the linearized theory is the fact that it describes the flow quite inexactly at a certain distance from the body of the wing. In fact, according to the linearized theory, the characteristic lines are always straight lines, and their inclination corresponds to the Mach number of the undisturbed flow. G. B. Witham has provided a relatively simple procedure for improving the flow field representation. He assumes that the flow variables predicted by the linearized theory are satisfactorily exact as far as their magnitude is concerned, but must be relocated spatially according to a corrected Mach wave shape. He uses

the first-order corrections obtained from the linearized theory for the local sonic velocity and the values for the total velocity obtained from the same theory, and uses these data to construct corresponding Mach waves, including eventual shock surfaces.

The Witham theory, in which the positions of the Mach waves are changed without changing the values of the flow variables, can be considered as a special case of the general method or "technique" introduced by Lighthill, which he calls a "technique for rendering approximate solutions to physical problems uniformly valid". In this technique—which is based on the methods used by H. Poincaré in his investigations on celestial mechanics—in addition to developing the dependent unknowns in series of successive terms as functions of some parameters, the independent variables, or a number of independent variables, are also developed as functions of the same parameters. By this trick in domains where the dependent variables have a singular behavior as functions of the independent variables they become easy to handle as functions of the new parameter which is used for a series development of the independent variable itself. This technique proved especially useful in some boundary layer problems which we shall mention later. As far as applications to nonviscous problems are concerned, the treatment of the mixed flow (hyperbolic and elliptic) about a sharp-edged conical wing by R. Vaglio-Laurin is worth mentioning.

In connection with higher-order approximations, we have to mention also the so-called method of linearized characteristics used by A. Ferri to build up three-dimensional flow fields from nonlinear two-dimensional flow fields, which are known by application of classical characteristic methods as used in two-dimensional supersonic aerodynamics since the fundamental works of Prandtl. Ferri finds that the characteristic surfaces of the three-dimensional flow field can be approximated by the envelopes of the characteristic surfaces of the system of two-dimensional flow fields. Hence the analysis of the three-dimensional flow is reduced to that of a flow field with given characteristic surfaces.

TRANSONIC FLOW

The transonic case is characterized by the fact that the difference between flight velocity U and sound velocity c , i.e. the quantity $(U - c)$, is small in comparison with either U or c . It is known that, at least in the case of a two-dimensional flow, for the disturbance potential ψ we arrive at a relatively simple nonlinear equation called Tricomi's equation:

$$(1 - M_\infty^2) \frac{\partial^2 \psi}{\partial x^2} + \frac{\partial^2 \psi}{\partial y^2} = (\gamma + 1) \frac{M_\infty}{c_\infty} \frac{\partial \psi}{\partial x} \frac{\partial^2 \psi}{\partial x^2}$$

where M_∞ denotes the Mach number of the main flow,

c_∞ , the sound velocity at infinity

γ , the ratio of the specific heats.

The nonlinear term of this equation contains the product $(\partial\psi/\partial x) \times (\partial^2\psi/\partial x^2)$; Oswaittsch and Keune proposed to replace the derivative of the u component of the horizontal velocity, $\partial^2\psi/\partial x^2$, by a value which is taken as independent of the coordinate y , but may vary step-wise as we proceed along the flow. They arrived in this way at very useful results for the computation of transonic flows around wings and bodies.

To a certain extent, useful results have been achieved for transonic flow calculations by the so-called Kármán-Tsien method, which introduced a "hypothetic fluid" with a simplified pressure-density relation valid in a limited Mach number range. This idea was further developed and improved by S. Tomotika and K. Tamada.

On the other hand, the theories concerning exact solutions of the Tricomi equation (particularly the question, in which cases do we obtain continuous solutions and in which cases do shocks appear) the problem of uniqueness of the solution has not made sufficient progress in the last ten years.

An attempt to obtain approximate but useful solutions of transonic flow problems replaces the differential equation for the disturbance potential by a system of difference equation. K. Friedrichs and his collaborators used this method; they put the problem into a computing machine. If the problems are properly formulated for the computing device, one can obtain fair approximations even for flows containing discontinuities (shocks), without an elaborate discussion concerning the existence or nonexistence of continuous solutions. Such formulations can also be used in the case of detached shocks in hypersonic flow around blunt bodies.

HYPERSONIC FLOW

The hypersonic speed range is characterized by the fact that the sonic velocity c is small compared with the flight velocity U . The interest in this speed range was recently very much enhanced by the problems connected with missile design, especially with the design of re-entry vehicles and nose cones.

If we first consider the flow against an inclined surface, for example the case of a wedge with small apex angle, the theory of inviscid fluids predicts attached and straight shock waves which slightly deflect the flow, so that the streamlines practically become parallel to the wedge surfaces. Hence the flow picture is very similar to that assumed in the model treated by Isaac Newton. The essential difference is that according to the Newton model the fluid particles move in parallel straight lines until they hit the surface, and then are deflected into a motion along the body surface, whereas according to the ideal-flow theory they are deflected at the shock surface which, however, lies very near to the body surface. Thus for a small angle of inclination—both for the case of the

two-dimensional wedge and that of the axisymmetrical cone—we obtain the result that the pressure acting on the surface element is given by

$$p = \frac{\rho}{2} U^2 . 2 \sin^2 \beta$$

where ρ is the density in the undisturbed fluid, U the velocity of same, and β the angle of inclination of the surface.

We may call a flow of this nature a Newtonian flow. The actual evidence is, of course, strongly modified by two factors. First, the presence of the solid surface produces viscosity effects, i.e. a boundary layer; second, no mathematically exact sharp edge exists, and therefore one always obtains a kind of detached shock with very large curvature near the front portion. The real picture of the flow, therefore, looks more like the one for the case of a body with a blunt edge, where the “equivalent body” corresponds in a broad sense to the domain occupied by the boundary

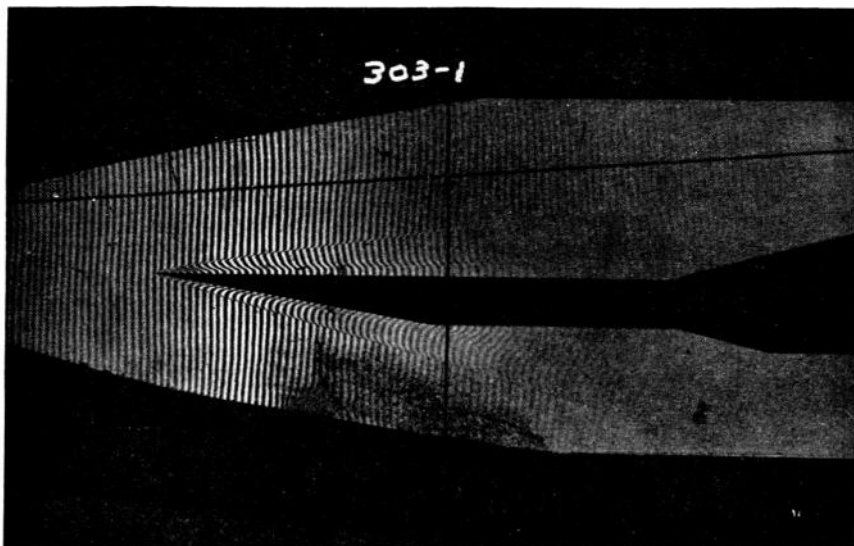

FIG. 7. Interferogram of flow along a flat plate.

layer. This description even applies to the flow observed in the case where the undisturbed flow is parallel to one surface of the unsymmetric wedge (Fig. 7). Furthermore, the large curvature of the detached shock wave introduces vorticity in the inviscid domain of the flow between the shock and the boundary layer.

Nevertheless, the rules of the Newtonian flow can be accepted as fair approximations for two- and three-dimensional flows. If the body surface is curved, the flow in the inviscid region is necessarily curved, and a

correction for the Newtonian law can be obtained by computing the effect of "centrifugal forces" between the shock and the body surface. Such a correction was suggested by A. Busemann at an early date (*Handbuch der Naturwissenschaften*, 1933) and recently further developed by H. R. Ivey and R. R. Morissette; furthermore by H. R. Ivey, E. B. Klinker, and E. N. Bowen.

If we consider a blunt body—for example a cylindrical or spherical body exposed to a flow hitting the body normal to its surface—two considerations have to be introduced.

First, the value of the pressure at the stagnation point is unknown. For an incompressible fluid we expect $p = p_0 + \rho/2U^2$ but even if we neglect for the time being gas-kinetical and chemical changes in the fluid, at the stagnation point we have to obtain temperatures of the order of the stagnation temperature of the ideal gas. Hence the pressure is influenced by the thermodynamic process, which was unknown to Newton. This is evident if we consider that he computed, for example, the sound velocity assuming an isothermal compression process.

In fact there are in addition changes in the distribution of the thermal energy between the several kinds of degrees of freedom in the gas molecules; at the high temperatures produced by the shock we certainly will encounter dissociation and recombination of atoms. Heat transfer effects will modify the temperature and pressure distribution between the shock and the surface.

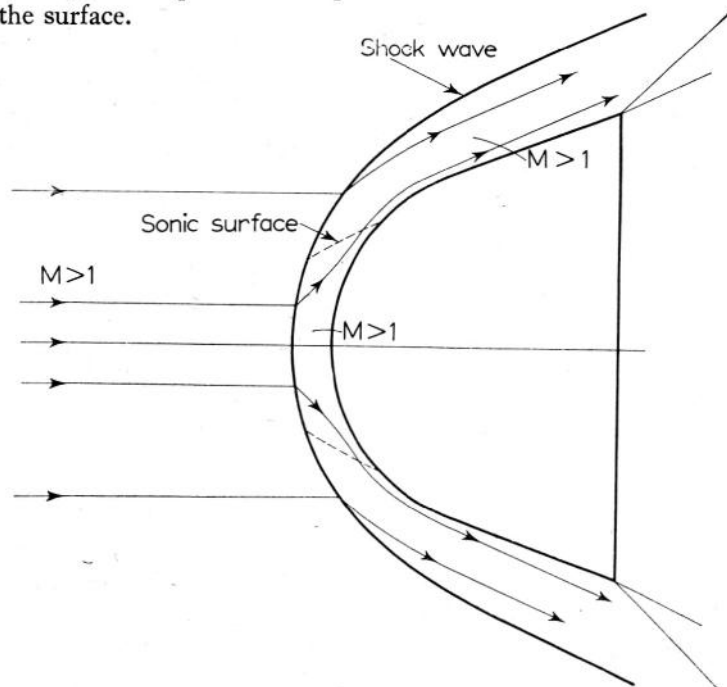

FIG. 8. Blunt body in hypersonic flow.

The second consideration which further complicates the problem is the fact that we have a mixed flow problem: whereas in the case of the sharp wedge or ogive the flow in the inviscid region was supersonic on both sides of the shock wave, we now have downstreams of the shock a subsonic region followed by a supersonic domain.

Nevertheless, if we consider the general type of flow shown schematically in Fig. 8, we can see that, at least in the neighborhood of the stagnation region, the fate of the individual gas particles is not very different from that assumed in Newton's model. The shock surface approximately follows the body surface and the individual streamlines show that the particles broadly speaking are deflected from their initial direction to the direction along the body surface. Correspondingly, we obtain a quasi-Newtonian pressure distribution in the sense that the local pressure coefficient C_p is given by the formula:

$$C_p = C_{p \max} \sin^2 \beta$$

where $C_{p \max}$ is the local pressure coefficient at the stagnation point, and β is the local inclination of the surface relative to the flow direction.

Beyond this quasi-Newtonian pressure distribution, the attempt to determine the exact flow conditions in the region between the shock wave and the blunt body were not too successful until now. There are too many uncertainties: first, the location of the shock wave is uncertain; second, the sonic line can be determined only by a kind of iteration process, so that the subsonic and supersonic flow regions really match. Even if we stick to ideal gas laws, we cannot consider the flow as a potential flow, because of the vorticity produced in the shock region. The best approximation is that of constant vorticity along streamline in the two-dimensional case, and constant vorticity flow in the axial symmetric case. The computation certainly needs the help of electronic computers. Among the iteration methods, one used by the Soviet mathematicians Dorodnitsyn and Belotserkovski is reported to be quite successful.

The flow beyond the sonic line can be calculated by the method of characteristics. Recent publications of H. M. Lieberstein and P. R. Garabedian, M. D. Van Dyke, R. Vaglio-Laurin and A. Ferri deal with this problem.

They consider the inverse case: to assume a shock shape and find the corresponding body shape.

Figure 9 shows experimental pressure measurements for the case of a body consisting of a long circular cylinder with a hemispherical forward portion. The measurements were made at $M = 7.7$.

Near the stagnation point the pressure distribution corresponds to the quasi-Newtonian rule; on the shoulder where the curvature of the meridian section discontinuously changes apparently the rate of the pressure drop can be described by the assumption of a Prandtl-Mayer expansion process. Then, however, one would expect that the pressure would rather

quickly approach the final value (which because of the expansion in the wake is slightly below the value corresponding to the undisturbed flow). However, observation shows a very slow decrease; evidently this corresponds to an expanding shock wave surface over the cylindrical portion of the body.

This process was made understandable by application of the analogy between an unsteady motion, in which the flow picture remains similar to itself, and a steady flow, in which the length co-ordinate in the flight direction replaces the time co-ordinate of the unsteady process. A characteristic example of such unsteady solutions is the well-known solution which G. I. Taylor obtained during World War II for the problem of a violent spherical explosion. The propagation of a weak explosion with sound velocity can be considered as one limiting case, namely the case where the energy introduced by the explosion is small relative to the enthalpy of the gas involved. Taylor's problem is the other extreme: he assumed that the energy introduced is very large in comparison with the enthalpy of the gas in which the explosion occurs. However, Taylor's unsteady solution is three-dimensional in space; thus it cannot be used immediately for the description of a steady flow (except maybe in a four-dimensional space). Recently S. C. Lin solved the problem of a cylindrical violent explosion, and this computation led to the "blast wave theory" of hypersonic motion. Especially the variable distance between the shock wave and the surface of a long body can be computed by this method, in that one builds up the flow picture in consecutive perpendicular planes of a sequence of solutions for the unsteady cylindrical explosion at various states of the propagation process. The location of the shock wave of the steady flow problem is identical with the location of the expanding wave at the corresponding time element. One assumes that the explosion occurs at the cylindrical body surface, and the energy introduced by the explosion corresponds to the energy introduced into the fluid by the resistance of the body; it is in general time-dependent. It is seen from Fig. 9 that the results of the blast wave theory are in fair agreement with the observations. From the rather extensive literature on the subject, the contributions of A. Sakurai, S. C. Lin, L. Lees and T. Kubota, and also H. K. Cheng and A. J. Pallone can be mentioned. Independently, the theory was also developed in Russia, where the self-similar process was named "automodel". Especially L. Sedov and his collaborators worked on the theory of strong explosions. Grodzovski, Chernyi, and Stanyukovich found and employed the analogy between the unsteady and the steady motion.

The true problem of the blunt body exposed to hypersonic flow involves aerothermochemistry, since the temperatures reached behind the shock are so high that the air dissociates. However, before discussing this problem, we want to consider some general questions related to boundary layer theory.

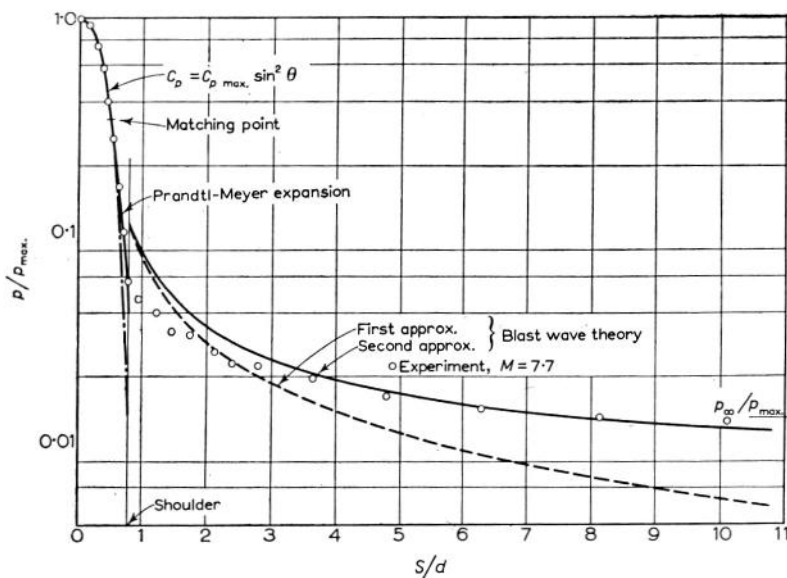

FIG. 9. Pressure distribution on a hemisphere-cylinder combination.

BOUNDARY LAYER THEORY

In 1954 we celebrated the fiftieth anniversary of the concept of the boundary layer, in view of the fact that Ludwig Prandtl presented the fundamentals of the boundary layer theory in 1904 to the International Congress for Mathematics assembled in Heidelberg, Germany. For half a century the new concept proved to be one of the most fruitful ideas in fluid mechanics. The anniversary volume, entitled *Fifty Years Boundary Layer Research*, can give an approximate picture of the main aspect of this development. We also want to mention that in 1947 Loitsianski published a review of the contributions of Soviet scientists to the boundary layer theory.

Most investigations of boundary layer problems refer to plane or axisymmetric flows. We will mention later more general three-dimensional cases. At this point we only want to mention that Mangler succeeded in reducing, by a transformation, the axisymmetric case to a corresponding two-dimensional problem.

There are two different approaches which were used in the practical solution of boundary-layer problems, especially in the case of incompressible fluids. One is the so-called integral method suggested by me and first used by K. Pohlhausen. This method reduces the problem of finding a solution of a partial differential equation to that of a solution of an ordinary differential equation. Recently, an essential improvement of the method was achieved by I. Tani. The second approach consists also of a reduction of the partial differential equation to an ordinary differential

equation, by looking for special pressure distributions along the wall which allow similar solutions through the crosssections of the boundary layer. Falkner, Skan, Hartree, and Thwaites, in the early thirties, excelled in the development of such "similarity solutions".

As far as laminar but compressible boundary-layer problems are concerned, some special cases were solved before 1946 by A. Busemann, myself, H. S. Tsien, Hanzsche, Wendt, L. Crocco, and H. W. Emmons and J. G. Brainerd. Special attention was given to the heat-transfer aspect of the problems.

The treatment of the compressible boundary layer in more general cases was greatly facilitated by a clever transformation of the independent variable across the boundary layer, which takes into account the variable density. Such a transformation apparently has been first suggested by A. A. Dorodnitsyn, and carried out by L. Howarth, K. Stewartson and C. R. Illingworth.

Since this transformation essentially reduces the problem of the compressible boundary layer to the incompressible case, the methods mentioned above could be applied to a broad field of problems. Thus the integral method could be used for the flow about airfoils and bodies of revolution in supersonic flight. We can mention the contributions of L. E. Kalikhman, H. Weil, P. A. Libby and M. Morduchow, I. E. Beckwith, D. N. Morris and J. W. Smith, and others.

Also, the method of similar solution was combined with the Stewartson-illingworth transformation by L. Crocco and C. B. Cohen, and they extended the method of Thwaites by putting together a sequence of similarity solutions. This procedure was further developed by C. B. Cohen and E. Reshotko. It appears that the work of S. Levy allows a great degree of generality in the formulation of the problem: large temperature changes, including viscous heating and arbitrary values of the Prandtl number. This nondimensional quantity was taken in many previous investigations to be equal to unity.

For a long time the theory of the laminar boundary layer was considered as having more academic than practical values. Recently it was found that there are two reasons why the study of the laminar boundary layer is interesting also from the viewpoint of practical applications. First, there is the problem of re-entry of blunt bodies into the atmosphere. The highest value of heat transfer occurs at the stagnation point, and at the beginning the boundary layer probably has laminar structure. Second, the flight of missiles and vehicles at high altitude, i.e. in a medium of extremely low density enhances the interest for conditions at small Reynolds numbers.

As we mentioned before, the problem of the boundary layer behind a detached shock produced by hypersonic motion of a blunt body is complicated by the changes in the physical and chemical nature of the gas at the high temperatures produced by the shock. The main changes

to be expected are: changes in the distribution of the thermal energy over the degrees of freedom of the gas molecules; dissociation; and finally, ionization. The first phenomenon leads especially to a variation in the value of the specific heat, and particularly of the ratio between the specific heats; the dissociation may fundamentally change the mechanism of heat transfer by introducing the possibility of diffusion. It was found that ionization does not essentially influence the heat transfer; however, the fact that the gas becomes conductive raises the question whether there is a practical way to change the structure of the boundary layer by artificially-imposed electromagnetic field effects. In addition, the behavior of an ionized gas against radar waves is of practical interest in view of problems of detection and communication in general.

Concerning the methods for theoretical investigation of the influence of variable physical and chemical characteristics, two limiting cases appear as relatively simple: equilibrium state and frozen state, for example assuming a high grade of dissociation immediately behind the shock, and considering this grade of dissociation constant over the flow field, recombination in this case would be restricted to the immediate neighborhood of the body surface. Then, of course, an important question of great practical value arises: whether it is possible to prevent recombination at the surface by so-called noncatalytic surface coating. The application of such materials would essentially diminish heat transfer in the critical region and distribute the heat produced by the shock over a larger region.

The more exact investigation of variable concentration according to some rate law of dissociation and recombination is more complicated, but the calculation can be carried out numerically at least for the stagnation point. The most extensive investigation of stagnation point conditions is due to J. A. Fay and F. R. Riddell. The most complete discussion of the entire problem of the hypersonic boundary layer is due to L. Lees. He found that two assumptions: equilibrium state and Lewis number (ratio between thermal conductivity and diffusion coefficient) equal to unity, make the computation relatively simple. Thus the possibility arises to carry out an exact investigation for the stagnation point region, and to use the ratio between the heat transfer at various points furnished by a simplified theory for an estimate of the heat transfer at other points.

In general it seems that the various assumptions concerning the dissociation process do not change the heat transfer values more than about 40-50 per cent.

Investigations of boundary layer flow with mass transfer are important in view of the possibilities of cooling by injection of material, or also absorption of heat by melting or evaporation of the surface, generally called "ablation".

A remarkable phenomenon was found by experiments on boundary layers in hypersonic flow over a flat plate parallel to the flow direction, or inclined to the flow direction at a small angle (sharp wedge). It appears

that in such cases, the fundamental assumption of the usual theory, that the pressure in the boundary layer is equal to the pressure in the external flow is quite wrong. One finds considerable pressure increase, apparently induced by the boundary layer itself. We mentioned that probably due to the finite dimension of the leading edge the flow picture corresponds to a detached shock caused by a kind of equivalent body, corresponding to the domain occupied by the boundary layer. Then the motion inside this equivalent body has the general character of a flow through a pipe with increasing crosssection, and this kind of motion produces the increased pressure. This phenomenon was called hyper-sonic boundary layer-shockwave interaction.

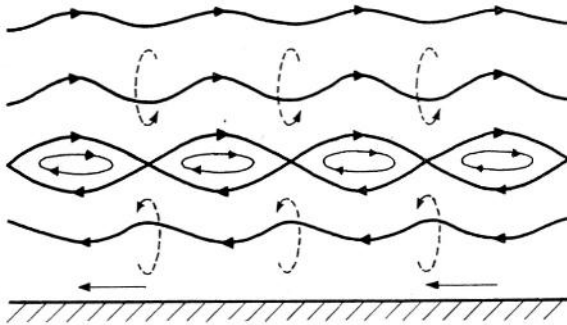

FIG. 10. Illustration to Görtler's theory of transition between laminar and turbulent boundary layer flow.

There is no satisfactory criterion which would permit the prediction of the transition from laminar flow in the boundary layer to turbulent flow, for example in the case of a blunt body. It was found both theoretically and experimentally that cooling of the surface helps in keeping the flow laminar. This point has great practical importance because the heat transfer through a turbulent boundary layer is in any case much greater than the transfer through a laminar layer.

Concerning the general problem of stability of the laminar boundary layer, the mathematical theory shows excellent agreement with experiment, as far as the damping or the increasing of oscillations are concerned, especially after C. C. Lin corrected Schlichting's original numerical calculations. However, this does not mean that we really understand the mechanism of transition. Recently, Emmons suggested the following mechanism: turbulence is created at isolated spots, and these spots cause contamination of the downstream flow. According to Theodoresen the turbulence originates with the formation of horseshoe vortices which are formed near the walls and penetrate into the field. Pfenninger and Lachmann observed similar phenomena in their experiments to keep the boundary layer flow laminar by means of suction. Görtler proposed as a starting point for the understanding of the transition phenomena the Schlichting-Tollmien waves, but pointed out that the circulation around

the curved streamlines plays a role in the transition, which according to him is an essentially three-dimensional phenomenon. T. Tani and F. R. Hama studied the influence of isolated roughnesses on the transition.

Most investigations mentioned above refer to two-dimensional planes of axisymmetrical flow. In recent years there has been considerable effort devoted to the interesting problems of the boundary layer behavior when three velocity components are involved. Such flows arise in a variety of ways; of particular interest for aeronautical applications are the flows over swept wings, over axisymmetrical bodies at angle of attack, and in rotating blade systems. Recently J. K. Moore provided an excellent survey of developments in three-dimensional boundary layer theory.

The boundary layer on swept wings influences the stalling and lateral control of the wing and has been the subject of considerable research. This problem is idealized by considering the wing to be infinite so that changes in the spanwise direction are neglected. One can distinguish between a boundary layer normal to the leading edge, and a spanwise boundary layer. This consideration leads, for incompressible flows, to the important "independence principle". According to this the two boundary layers are independent; one calculates first the chordwise boundary layer in the usual way, and then the spanwise boundary layer. The combination of the two boundary layers permits the streamlines within the boundary layer to be constructed. In general these streamlines differ from those in the external flow, so that secondary flows arise. Research on this problem was carried out by L. Prandtl, Struminsky, R. J. Jones and W. R. Sears.

For the incompressible case the density depends on both the chordwise and spanwise velocity components, so that the momentum equations in the two directions are "coupled" through the energy equation. The well-known Crocco integral applies in this case under certain restrictions. However, the most general case of chordwise pressure gradient and heat transfer requires simultaneous solution of the chordwise and spanwise momentum equations. Recently E. Reshotko and I. E. Beckwith provided a solution for the boundary layer and heat transfer characteristics in the neighborhood of the stagnation line, such as arises at the leading edge of a blunt-nosed, swept wing. This analysis shows that significant reductions in heat transfer can be achieved by sweeping the leading edge of a wing; thus the concept of sweep is seen to be useful also for hypersonic flight.

THEORY OF TURBULENCE

The theory of turbulence has two separate aspects. Evidently there is some analogy between the random motion of molecules in laminar flow and the random motion of eddylike formations in the turbulent flow. The random motion of molecules leads to definite laws of molecular viscosity, heat conduction, and diffusion. In a similar way, the random motion we observe, on a much larger scale, in the turbulent flow of rivers, canals, pipes and boundary layers apparently also results in definite laws for

momentum transfer, energy transfer and the transfer of matter which we call turbulent friction, heat transfer and diffusion respectively. This analogy between the molecular and the turbulent processes was recognized and treated at a rather early date by Osborne Reynolds. The great difference between the two concepts is the fact that in the case of the molecular random motion the elements are well defined as molecules, whereas in the case of the turbulent motion they are not given *a priori*. Hence, whereas in the first case the Boltzmann theory shows the right way to a definite theoretical solution of the problem, in the case of turbulent motion new principles must be found.

Due to this situation, the turbulence theory developed in two essentially different directions. One school of thought endeavored to find half empirical relations which would lead to definite rules for the prediction of the turbulent friction, heat transfer and diffusion phenomena. On the other hand, very interesting ideas were proposed for building up a systematic statistical theory of turbulence.

As far as the first lines of development are concerned, for the case of an incompressible fluid a satisfactory state of affairs was reached by the introduction of a concept of the mixing length—as a kind of generalization of the mean free path of the kinetic gas theory—due to L. Prandtl, and then, I believe, by the logarithmic law for the velocity distribution, which I found in 1930. Assuming the validity of the logarithmic law for the portion of the flow field which is mainly influenced by the wall, and the so-called “velocity decrement” law for the rest of the field, the turbulent flow in the boundary layer, in a circular pipe and in a two-dimensional channel, can be predicted for given Reynolds numbers. The application of the integral method used by myself and Pohlhausen, also mentioned in connection with the laminar boundary layer, makes it also possible to calculate general boundary layer problems. In this direction, F. Clauser recently proposed interesting new concepts and computing methods.

We have to mention that the concept of local similarity of the turbulent flow-picture is an important factor as a lead for further development of the theory. When I first presented the idea in 1930, its formulation may have been somewhat over-simplified, but I believe—especially after the concept was clarified in some of my own publications together with C. C. Lin, and those of C. C. Lin and his collaborators—it will have considerable influence on further development of the theory of turbulence. The main need today is for a reliable prediction of the practically important quantities, especially skin friction and heat transfer for compressible fluids, particularly for supersonic boundary layers at higher Mach numbers. Figure 11 convincingly shows the discrepancies between the predictions derived from various proposed “theories”.

The diagram, taken from NACA Report TN 3097 (1954), presents the ratio between the predicted value of the skin friction coefficient in a compressible boundary layer and the well-known value of the same co-

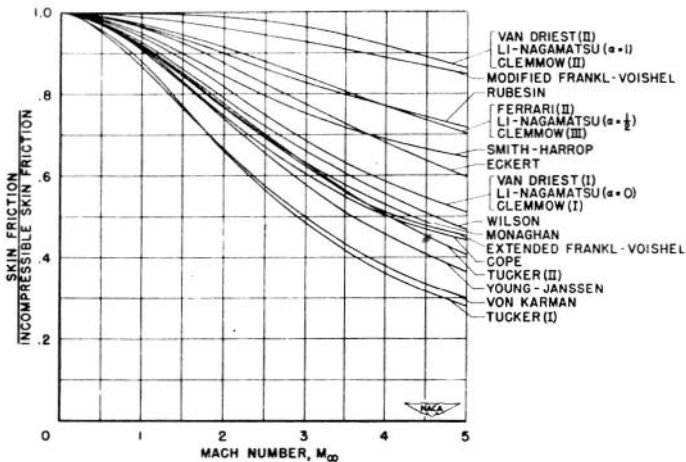

FIG. 11. Results of various analyses of turbulent skin friction for compressible flow over an insulated flat plate (NACA TN 2097).

efficient for incompressible flow. The experimental value for $M=4$ is about 0.5. I notice that the value which goes with my name is closer to the experimental value than many others deduced by later elaborate theories. I considered my so-called theory, which I proposed more than twenty years ago, as a "guestimate". I simply substituted for the density, in the formula for incompressible flow, the value corresponding to the stagnation temperature which develops at the wall. This procedure naturally underestimates the skin friction, since to be correct some approximately determined average temperature should be used. Unfortunately the results of the theories of the Soviet scientists A. A. Dorodnitsyn and L. A. Kalikhman are not included in the comparison.

The systematic development of a statistical theory of turbulence was initiated by G. I. Taylor (1935). He introduced the concept of isotropic turbulence, which was later modified and somewhat generalized by G. K. Batchelor to homogeneous turbulence. Batchelor's book, published by the Cambridge University Press in 1953, contains extremely valuable information on the developments of the statistical theory. Taylor proposed the average values of velocity correlations as a means of description of the turbulent flow. In 1938 L. Howarth and myself gave a general analysis of the correlations and initiated the branch of the statistical theory which can be designated as the "dynamics of turbulence". We arrived at a differential equation for the prediction of the variations of the correlation values with time, i.e. the propagation of the turbulence. G. I. Taylor himself introduced as an alternative for the correlation functions the representation of the turbulent fluctuations by spectral functions. Kampé de Fériet investigated the concept of the spectral tensor especially from the

mathematical point of view. The spectral viewpoint was adopted by Obukoff and Heisenberg in their general investigations. Perhaps the most important result of these developments is a universal law for the spectral function—i.e. turbulent energy *versus* wave number—which is valid for high frequencies and was found independently by A. N. Kolmogoroff and W. Heisenberg. S. Chandrasekhar made significant contributions in this direction of the development.

The theory of homogeneous turbulence—which covers the case of a turbulent fluctuation field without mean flow or the turbulent field superposed upon a uniform stream—is in relatively good shape. However, the more interesting and practically more important case, the theory of the mechanism of turbulent shear, is yet in a very initial phase. From a physical point of view, the main difficulty seems to be that for the momentum transfer the large eddies are mostly responsible, whereas the energy dissipation is performed by the small eddies. This causes a diffusion of energy from low to high frequencies which does not comply with Onsager's general energy transfer scheme which provides the real basis for Kolmogoroff's and Heisenberg's theories.

From the mathematical point of view, one could expect that the dynamic equation first written up by me, jointly with L. Howarth, would apply also to the general case of non-isotropic turbulence. However, this equation essentially predicts the fate of the second- and third-order correlations only if the higher correlations are known. I believe a real progress was made by the hypothesis that a so-called "quasi-normal joint-probability" (Gaussian probability) can be assumed for the velocity field.

This assumption makes it possible to express the fourth-order correlations by products of the second-order correlations. It was first suggested by Millionschikoff. Attempts were recently made to apply the hypothesis for the solution of the shear problem, by J. Proudman, W. H. Reid, T. Tatsumi, and A. Craya. Other approaches for the solution of the shear problem were made by S. Chandrasekhar, W. V. R. Malkus, J. M. Burgers, and M. Mitchner. All these theories are in an initial state. We are still far away from a theoretical deduction of the basic laws for shear and heat transfer which would give results being in agreement with experimental evidence. I believe that the refinement of the similarity concept has to play a role in the establishment of a final theory.

The experimental evidence on turbulent boundary layers and turbulent shear was very much enriched by the excellent work of experimenters such as L. Kovasznay, J. Laufer, A. A. Townsend, J. B. Schubauer, and others.

I mentioned before that "heavenly turbulence", i.e. the turbulent phenomena observed in gaseous clouds of cosmic dimensions fascinated the imagination of quite a number of mathematicians, astronomers, and aerodynamicists. It was one of the problems which contributed to the interest for the most recent branch of fluid mechanics: "magnetofluid-mechanics".

I may close with the remark that it appears to me that even in this so-called nuclear- or space-age, aerodynamics is not a science to be shelved as an obsolescent branch of the physical sciences. Of course, we may have to study more than in the past the methods and results of many sister sciences: in addition to mathematics, mechanics, and thermodynamics, also chemistry and electromagnetism. However, I hope that the future training of young aerodynamicists will be sufficiently forward-looking to enable them to cope with the problems of the future.

It is my agreeable duty to express my thanks and appreciation of the assistance of my friends P. A. Libby and C. C. Lin for their assistance in collecting the material treated in this lecture. Professor Libby collected the papers dealing with supersonic wing theory, slender aircraft, interference effects, higher approximations, hypersonic flow and boundary layer theory, C. C. Lin those dealing with the theory of turbulence. The choice of authors mentioned in the paper is somewhat arbitrary. I am also indebted to Professor Wallace D. Hayes for letting me have the galley proofs of his book on hypersonic flow written jointly with R. F. Probstein, which will appear in the near future. I. Tani prepared for me abstracts of important Japanese papers published in the last decade. The problems of flow in rarified gases, sometimes referred to as problems of supraaerodynamics, are not treated at all; the reader may find good summaries in the Proceedings of an International Conference held in Nice, France, in July 1958. Also the aeroelastic problems e.g. flutter at high speed, are only shortly mentioned.

TH. VON KÁRMÁN

BIBLIOGRAPHY

I. *Wing Theory*

- T. VON KÁRMÁN, *Supersonic Aerodynamics. Principles and Applications*, *J. Aero. Sci.*, Vol. 14, No. 7, pp. 373-409, 1947.
- R. T. JONES and D. COHEN, *Aerodynamics of Wings at High Speeds*, Section A, Vol. VII, *High Speed Aerodynamics and Jet Propulsion*, Princeton University Press, pp. 3-243, 1957.
- T. VON KÁRMÁN and N. B. MOORE, The Resistance of Slender Bodies Moving with Supersonic Velocities with Special Reference to Projectiles, *Trans. Amer. Soc. Mech. Engrs.*, Vol. 54, pp. 303-10, 1932.
- A. E. PUCKETT, *Supersonic Wave Drag of Thin Airfoils*, *J. Aero. Sci.*, Vol. 13, No. 9, pp. 475-84, September 1946.
- J. C. EVVARD, Use of Source Distributions for Evaluating Theoretical Aerodynamics of Thin Finite Wings at Supersonic Speeds, NACA TR 951, 1950.
- E. A. KRASILSHCHIKOVA, *Uchenye Zapiski* 154, *Mekhanika*, Vol. 4, 181-239, 1951. Translated as NACA TM 1383, 1956.
- R. T. JONES, The Minimum Drag of Thin Wings in Frictionless Flow, *J. Aero. Sci.*, Vol. 18, No. 2, pp. 75-81, February 1951.
- DORIS COHEN, The Warping of Triangular Wings for Minimum Drag at Supersonic Speeds, *J. Aero. Sci.*, Vol. 24, No. 1, pp. 67-8, January 1957.
- ANON, Conical Camber, *Aviat. Age*, Vol. 24, No. 2, p. 62, August 1957.

II. *Slender Wings and Aircraft*

- H. S. TSIEN, Supersonic Flow over an Inclined Body of Revolution, *J. Aero. Sci.*, Vol. 5, pp. 480-3, 1938.
- M. J. LIGHTHILL, Supersonic Flow Past Bodies of Revolution, ARC Reports and Memoranda 2003, 1945.
- J. B. BRODERICK, Supersonic Flow Round Pointed Bodies of Revolution, *Quart. J. Mech. and Appl. Math.*, Vol. 2, pp. 98-120, 1949.
- G. N. WARD, *Linearized Theory of Steady High-Speed Flow*, Cambridge University Press, 1955.
- R. T. JONES, Properties of Low-Aspect-Ratio Pointed Wings at Speeds Below and Above the Speed of Sound, NACA TR 835, 1946.
- H. J. ALLEN, Pressure Distribution and Some Effects of Viscosity on Slender Inclined Bodies of Revolution, NACA TN 2004, 1950.
- A. H. FLAX and H. R. LAWRENCE, The Aerodynamics of Low-Aspect-Ratio Wings and Wing-Body Combinations, *Proceedings, Third Anglo-American Aeronautical Conference*, pp. 363-98, 1951.
- M. C. ADAMS and W. R. SEARS, Slender Wing Theory Review and Extensions, *Aero. Sci.*, Vol. 20, No. 2, pp. 85-98, February 1953.

III. *Interference Effects*

- G. N. WARD, Supersonic Flow Past Slender Pointed Bodies, *Quart. J. Mech. and Appl. Math.*, Vol. 2, Part I, pp. 76-97, 1949.
- H. R. LAWRENCE and A. H. FLAX, Wing-Body Interference at Subsonic and Supersonic Speeds—Survey and New Developments, *J. Aero. Sci.*, Vol. 21, No. 5, pp. 289-324, May 1954.
- MAC C. ADAMS and W. R. SEARS, Slender Body Theory—Review and Extension, *J. Aero. Sci.*, Vol. 20, No. 2, pp. 85-98, February 1953.
- C. FERRARI, Interaction Problems, Section C, Vol. VII of *High-Speed Aerodynamics and Jet Propulsion*, Princeton University Press, Princeton 1957.
- G. K. MORIKAWA, A Non-Planar Boundary Problem for the Wave Equation, *Quart. Appl. Math.*, Vol. 10, No. 2, pp. 129-40, 1952.
- J. N. NIELSON and W. C. PITTS, Wing-Body Interference at Supersonic Speeds with an Application to Combinations with Rectangular Wings, NACA TN 2677, April 1952.
- S. H. BROWNE, L. FRIEDMAN and I. HODES, A Wing-Body Problem in a Supersonic Conical Flow, *J. Aero. Sci.*, Vol. 15, No. 8, pp. 443-52, August 1948.
- E. W. GRAHAM, P. A. LAGERSTROM, R. M. LICHER and B. J. BEANE, A Theoretical Investigation of the Drag of Generalized Aircraft Configurations in Supersonic Flow, Douglas Aircraft Co., Inc., Rep. SM-19181, July 1955.
- R. H. CRAMER, Wing-Body Interference at Supersonic Speeds—Recent Experimental Results and their Bearing on Advances in Theory, Presented at Navy Bureau of Ordnance Symposium on Aeroballistics, 13 May 1952.
- G. K. MORIKAWA, Supersonic Wing-Body Lift, *J. Aero. Sci.*, Vol. 18, No. 4, pp. 217-28, April 1951.
- A. H. SACKS, Vortex Interference Effects on the Aerodynamics of Slender Airplanes and Missiles, *J. Aero. Sci.*, Vol. 24, No. 6, pp. 393-402, June 1957.
- A. BUSEMANN, Aerodynamischer Auftrieb bei Überschallgeschwindigkeit, Fifth Volta Congress, Reale Accademia D'Italia, 1935.
- C. FERRARI, Campi di corrente ipersonora attorno a solidi di rivoluzione, *L'Aerotecnica*, Vol. 17, Fasc. 6, pp. 507-18, 1937.
- A. FERRI, Application of the Method of Characteristics to Supersonic Rotational Flow, NACA TR 841, 1946.

- A. FERRI and J. H. CLARKE, On the Use of Interfering Flow Fields for the Reduction of Drag at Supersonic Speeds, *J. Aero. Sci.*, Vol. 24, No. 1, pp. 1-18, January 1957.
- K. OSWATITSCH, The Area Rule, *Appl. Mech. Rev.*, Vol. 10, No. 12, pp. 543-5, December 1957.
- W. R. SEARS, On Projectiles of Minimum Wave Drag, *Quart. Appl. Math.*, Vol. 14, pp. 361-6, 1947.
- W. HAACK, *Geschossformen kleinsten Wellenwiderstandes*, Lilienthal-Gesellschaft, Bericht 139, pp. 14-21, 1941.
- W. D. HAYES, Linearized Supersonic Flow, North American Aviation Report AL-222, June 1947.
- A. FERRI, Recent Theoretical Work in Supersonic Aerodynamics at the Polytechnic Institute of Brooklyn, *Proceedings of the Conference on High-Speed Aeronautics*, Polytechnic Institute of Brooklyn, January 1955.
- A. FERRI, J. H. CLARKE and L. TING, Favorable Interference in Lifting Systems in Supersonic Flow, *J. Aero. Sci.*, Vol. 24, No. 11, pp. 791-804, November 1957.
- R. T. JONES, Minimum Wave Drag for Arbitrary Arrangements of Wings and Bodies, NACA TN 3530, February 1956.
- H. LOMAX and M. A. HEASLET, Recent Developments in the Theory of Wing-Body Wave Drag, *J. Aero. Sci.*, Vol. 23, No. 12, pp. 1061-74, December 1956.

IV. Non-linear Theories.—Higher Approximations

- A. BUSEMANN, Aerodynamischer Auftrieb bei Überschallgeschwindigkeit, *Luftfahrtforsch.*, Vol. 12, p. 210, 1935.
- K. O. FRIEDRICH, Formation and Decay of Shock Waves, *Commun. Pure Appl. Math.*, Vol. 1, p. 211, 1948.
- M. J. LIGHTHILL, Higher Approximations, Section E, Vol. VI, *High-Speed Aerodynamics and Jet Propulsion*, Princeton University Press, pp. 345-489, 1954.
- M. VAN DYKE, First- and Second-Order Theory of Supersonic Flow Past Bodies of Revolution, *J. Aero. Sci.*, Vol. 18, pp. 161-178, 1951.
- G. B. WHITHAM, The Flow Pattern of a Supersonic Projectile, *Commun. Pure Appl. Math.*, Vol. 5, p. 301, 1952.
- M. J. LIGHTHILL, A Technique for Rendering Approximate Solutions to Physical Problems Uniformly Valid, *Phil. Mag.*, Series 7, Vol. 40, pp. 1179-1201, 1950.
- M. J. LIGHTHILL, The Shock Strength in Supersonic Conical Fields, *Phil. Mag.*, Series 7, Vol. 40, pp. 1202-23, 1950.
- Y. H. KUO, Viscous Flow Along a Flat Plate Moving at High Supersonic Speed, *J. Aero. Sci.*, Vol. 23, No. 2, pp. 125-36, 1956.
- H. S. TSIEN, The Poincaré-Lighthill-Kuo method, *Advanc. appl. Mech.*, Vol. 4, Academic Press Inc., 1956.
- A. FERRI and R. VAGLIO-LAURIN, On Conical Flows of Mixed Type, Polytechnic Institute of Brooklyn Aeronautical Laboratory Report No. 306, April 1956.
- S. KAPLUN and P. A. LAGERSTROM, Asymptotic Expansion of Navier-Stokes Solution for Small Reynolds Numbers, *IX International Congress of Applied Mechanics*, Vol. 3, pp. 177-86, 1957.
- S. KAPLUN, The Role of Coordinate Systems in Boundary Layer Theory, *J. Appl. Math. Phys.*, Vol. 5, No. 2, pp. 111-35, 1954.
- A. FERRI, The Linearized Characteristics Method and its Application to Practical Non-linear Supersonic Problems, NACA TR 1102, 1952.

V. Hypersonic Flow

- L. LEES, Recent Developments in Hypersonic Flow, *Jet Propulsion*, Vol. 27, No. 11, pp. 1162-78, November 1957.
- J. LOGAN, Relaxation Phenomena in Hypersonic Aerodynamics, Institute of the Aeronautical Sciences, Preprint No. 728, January 1957.

- S. FELDMAN, *The Chemical Kinetics of Air at High Temperatures: A Problem in Hypersonic Aerodynamics*, Heat Transfer and Fluid Mechanics' Institute, California Institute of Technology, 1957.
- M. CAMAC, J. CAMM, J. KECK and C. PETTY, Relaxation Phenomena in Air Between 3000 and 8000°K, AVCO Research Laboratory, Report No. 22, 13 March 1958.
- M. J. LIDTHILL, Dynamics of a Dissociating Gas, Part I—Equilibrium Flow, Aeronautical Research Council 18,837. Also *J. Fluid. Mech.*, Vol. 2, Part I, pp. 1–32, January 1957.
- N. C. FREEMAN, Dynamics of a Dissociating Gas, III—Non-Equilibrium Theory, AGARD Report 133, July 1957.
- W. D. HAYES, *Some Aspects of Hypersonic Flow*, The Ramo-Wooldridge Corporation, 4 January 1955.
- W. D. HAYES, *Hypersonic Flow Fields at Small-Density Ratio*, The Ramo-Wooldridge Corporation, 12 May 1955.
- W. CHESTER, Supersonic Flow Past a Bluff Body with a Detached Shock, Part I—Two-Dimensional Body, *J. Fluid. Mech.*, Vol. 1, Part 4, pp. 353–65, October 1956.
- N. C. FREEMAN, On the Theory of Hypersonic Flow Past Plane and Axially-Symmetric Bluff Bodies, *J. Fluid Mech.*, Vol. 1, Part 4, pp. 366–87, October 1956.
- K. HIDA, An Approximate Study on the Detached Shock Wave in Front of a Circular Cylinder and a Sphere, *J. Phys. Soc. Japan*, Vol. 8, No. 6, pp. 740–5, November–December 1953.
- G. I. TAYLOR, The Formation of a Blast Wave by a Very Intense Explosion, Part I—Theoretical Discussion. Part II—The Atomic Explosion of 1945. *Proc. Roy. Soc. A*, Vol. 201, No. 1065, pp. 159–86, March 1950.
- S. C. LIN, Cylindrical Shock Waves Produced by Instantaneous Energy Release, *J. Appl. Phys.*, Vol. 25, No. 1, pp. 54–7, January 1954.
- A. SAKURAI, On the Propagation and Structure of the Blast Wave, Part I, *J. Phys. Soc. Japan*, Vol. 8, No. 5, pp. 662–9, September–October 1953; Part II, Vol. 9, pp. 256–66, April 1954.
- H. K. CHENG and A. J. PALLONE, Inviscid Leading-Edge Effect in Hypersonic Flow, *J. Aero. Sci.*, Vol. 23, pp. 700–02, July 1956.
- L. LEES and T. KUBOTA, Inviscid Hypersonic Flow over Blunt-Nosed Slender Bodies, *J. Aero. Sci.*, Vol. 24, No. 3, pp. 195–202, March 1957.
- P. R. GARABEDIAN and H. M. LIEBERSTEIN, On the Numerical Calculation of Detached Bow Shock Waves in Hypersonic Flow, *J. Aero. Sci.*, Vol. 25, No. 2, pp. 109–18, February 1958.
- M. D. VAN DYKE, The Supersonic Blunt-Body Problem—Review and Extension, *Inst. Aero. Sci.*, Preprint No. 801, January 1958.
- R. VAGLIO-LAURIN and A. FERRI, Theoretical Investigation of the Flow Field About Blunt-Nosed Bodies in Supersonic Flight, Gruen Applied Science Laboratories Inc., Technical Report No. 54, February 1958.

VI. Boundary Layer

- D. R. CHAPMAN and M. W. RUBESIN, Temperature and Velocity Profiles in the Compressible Laminar Boundary Layer with Arbitrary Distribution of Surface Temperature, *J. Aero. Sci.*, Vol. 16, No. 9, pp. 547–65, September 1949.
- C. CROWN, The Laminar Boundary Layer at Hypersonic Speeds, NAVORD Report 2299, 1952.
- G. B. W. YOUNG and E. JANSSEN, The Compressible Boundary Layer, *J. Aero. Sci.*, Vol. 19, No. 4, pp. 229–36, 288, April 1952.
- A. A. DORODNITSYN, Laminar Boundary Layer in a Compressible Gas, *Dokl. Akad. Nauk, SSSR*, Vol. (34) No. 8, 1942.

- L. HOWARTH, Concerning the Effect of Compressibility on Laminar Boundary Layers and their Separation, *Proc. Roy. Soc., A*, Vol. 194, p. 16, 1948.
- K. STEWARTSON, Correlated Compressible and Incompressible Boundary Layers, *Proc. Roy. Soc., A*, Vol. 200, p. 84, 1949.
- C. R. ILLINGWORTH, Steady Flow in the Laminar Boundary Layer of a Gas, *Proc. Roy. Soc., A*, Vol. 199, p. 533, 1949.
- L. E. KALIKHMAN, Heat Transmission in the Boundary Layer, NACA TM 1229, 1949.
- H. WEIL, Effects of Pressure Gradient on Stability and Skin Friction in Laminar Boundary Layers in Compressible Fluids, *J. Aero. Sci.*, Vol. 18, No. 5, pp. 311-18, May 1951.
- P. A. LIBBY and M. MORDUCHOW, Method for Calculation of Compressible Laminar Boundary Layer with Axial Pressure Gradient and Heat Transfer, NACA TN 3157, January 1954.
- I. E. BECKWITH, Heat Transfer and Skin Friction by an Integral Method in the Compressible Laminar Boundary Layer with a Streamwise Pressure Gradient, NACA TN 3005, September 1953.
- D. N. MORRIS and J. W. SMITH, The Compressible Laminar Boundary Layer with Arbitrary Pressure and Surface Temperature Gradients, *J. Aero. Sci.*, Vol. 20, No. 12, pp. 805-18, December 1953.
- L. CROCCO and C. B. COHEN, Compressible Laminar Boundary Layer with Heat Transfer and Pressure Gradient, *50 Jahre Grenzschichtforschung*, pp. 280-93, Friedr. Vieweg Braunschweig, 1955.
- C. B. COHEN and E. RESHOTKO, Similar Solutions for the Compressible Laminar Boundary Layer with Heat Transfer and Pressure Gradient, NACA TN 3325, 1955.
- C. B. COHEN and E. RESHOTKO, The Compressible Laminar Boundary Layer with Heat Transfer and Arbitrary Pressure Gradient, NACA TN 3326, 1955.
- S. LEVY, Effect of Large Temperature Changes (including Viscous Heating) upon Laminar Boundary Layers with Variable Free Stream Velocity, *J. Aero. Sci.*, Vol. 21, No. 7, pp. 459-74, July 1954.
- L. LEES, Laminar Heat Transfer over Blunt-Nosed Bodies at Hypersonic Flight Speeds, *Jet Propulsion*, Vol. 26, pp. 259-69, April 1956.
- J. A. FAY and F. R. RIDDELL, Theory of Stagnation Point Heat Transfer in Dissociated Air, *J. Aero. Sci.*, Vol. 25, No. 2, pp. 73-85, February 1958.
- P. H. ROSE and W. I. STARK, Stagnation Point Heat-Transfer Measurements in Dissociated Air, *J. Aero. Sci.*, Vol. 25, No. 2, pp. 86-97, February 1958.
- H. G. HAMMITT, A Preliminary Study of the Details of the Flow Field About a Flat Plate at Hypersonic Speeds, Princeton University, Department of Aeronautical Engineering Report No. 327, November 1955.
- S. F. SHEN, An Estimate of Viscosity Effect in Hypersonic Flow over an Insulated Wedge, *J. Math. Phys.*, Vol. 31, No. 3, pp. 192-205, October 1952.
- T-Y. LI and H. NAGAMATSU, Shock Wave Effects on the Laminar Skin Friction of an Insulated Flat Plate at Hypersonic Speeds, *J. Aero. Sci.*, Vol. 20, No. 5, pp. 345-55, May 1953.
- L. LEES and R. F. PROBSTEIN, Hypersonic Viscous Flow over a Flat Plate, Princeton University, Department of Aeronautical Engineering Report No. 195, April 1952.
- M. H. BERTRAM, An Approximate Method for Determining the Displacement Effects and Viscous Drag of Laminar Boundary Layers in Two-Dimensional Hypersonic Flow, NACA TN 2773, September 1952.
- J. M. KENDALL, JR., An Experimental Investigation of Leading Edge Shock Wave Boundary Layer Interaction at $M = 5.8$, *J. Aero. Sci.*, Vol. 24, No. 1, pp. 47-56, January 1957.

M. H. BERTRAM, Viscous and Leading-Edge Thickness Effects on the Pressures on the Surface of a Flat Plate in Hypersonic Flows, *J. Aero. Sci.*, Vol. 21, No. 5, pp. 430-1, June 1954.

S. M. BOGDONOFF and A. G. HAMMITT, Fluid Dynamic Effects at Speeds from $M = 11$ to 15, *J. Aero. Sci.*, Vol. 23, No. 2, pp. 108-116, February 1956.

A. G. HAMMITT and S. M. BOGDONOFF, Hypersonic Studies of the Leading-Edge Effect on the Flow Over a Flat Plate, *J. Amer. Rocket Soc.*, Vol. 26, No. 4, pp. 241-6, April 1956.

F. K. MOORE, Three-Dimensional Boundary Layer Theory, *Adv. Appl. Mech.*, Vol. 4, pp. 159-228, Academic Press, 1956.

E. RESHOTKO and I. E. BECKWITH, Compressible Laminar Boundary Layer over a Yawed Infinite Cylinder with Heat Transfer and Arbitrary Prandtl Number, NACA TN 3986, June 1957.

W. D. HAYES, The Three-Dimensional Boundary Layer, NAVORD Report No. 1313, U.S.N.O.T.S., May 1951.

L. HOWARTH, The Boundary Layer in Three-Dimensional Flow, *Phil. Mag.* (7), Vol. 42, pp. 239-43, 1951.

F. K. MOORE, Laminar Boundary Layer on Circular Cone in Supersonic Flow at Small Angle of Attack, NACA TN 2521, 1951.

A. MAGER, Three-Dimensional Laminar Boundary Layer with Small Cross-flow, *J. Aero. Sci.*, Vol. 21, No. 12, pp. 835-45, December 1954.

R. VAGLIO-LAURIN, Laminar Heat Transfer on Blunt-Nosed Bodies in Three-Dimensional Hypersonic Flow, WADC TN 58-147, May 1958.

H. L. DRYDEN, Transition from Laminar to Turbulent Flow at Subsonic and Supersonic Speeds, *Proceedings of the Conference on High-Speed Aeronautics*, Polytechnic Institute of Brooklyn, 20-22 January 1955, pp. 41-74.

C. C. LIN, On the Stability of Two-Dimensional Parallel Flows, *Quart. Appl. Math.*, Vol. 4, Part I, General Theory, pp. 117-42, 1945; Part II, Stability in an Inviscid Fluid, pp. 218-34, 1945; Part III, Stability in a Viscous Fluid, pp. 277-301, 1946.

L. LEES, The Stability of the Laminar Boundary Layer in a Compressible Fluid, NACA TR 876, 1947.

T. THEODORSEN, Mechanism of Turbulence, *Proceedings of Second Midwestern Conference on Fluid Mechanics*, pp. 1-16, 1952.

H. W. EMMONS, The Laminar-Turbulent Transition in a Boundary Layer, *J. Aero. Sci.*, Vol. 18, No. 7, pp. 490-98, July 1951.

H. L. DRYDEN, Recent Advances in the Mechanics of Boundary Layer Flow, *Adv. Appl. Mech.*, Vol. 1, pp. 1-40, Academic Press Inc., 1948.

F. H. CLAUSER, Turbulent Boundary Layer in Adverse Pressure Gradients, *J. Aero. Sci.*, Vol. 21, No. 2, pp. 91-108, February 1954.

F. H. CLAUSER, The Turbulent Boundary Layer, *Adv. Appl. Mech.*, Vol. 4, pp. 1-51, Academic Press Inc., 1956.

A. A. TOWNSEND, *The Structure of Turbulent Shear Flow*, Cambridge University Press, 1956.

D. COLES, The Law of the Wake in the Turbulent Boundary Layer, *J. Fluid. Mech.*, Vol. 1, Part 2, pp. 191-226, July 1956.

D. R. CHAPMAN and R. H. KESTER, Turbulent Boundary-Layer and Skin-Friction Measurements in Axial Flow along Cylinders at Mach Numbers Between 0.5 and 3.6, NACA TN 3097, 1954.

E. R. G. ECKERT, Engineering Relation for Friction and Heat Transfer to Surfaces in High-Velocity Flow, *J. Aero. Sci.*, Vol. 22, No. 8, pp. 585-6, August 1955.

P. A. LIBBY and R. J. CRESCI, Evaluation of Several Hypersonic Turbulent Heat Transfer Analyses by Comparison with Experimental Data, WADC TN 57-72, July 1957.

I. E. BECKWITH and J. J. GALLAGHER, Heat Transfer and Recovery Temperatures on a Sphere with Laminar, Transitional and Turbulent Boundary Layers at Mach Numbers of 2.00 and 4.15, NACA TN 4125, December 1957.

L. LEES, Convective Heat Transfer with Mass Addition and Chemical Reactions, *Third AGARD Combustion and Propulsion Panel Colloquium*, Palermo, Sicily, 17-21 March 1958.

S. SCALA and G. W. SUTTON, The Two-Phase Hypersonic Laminar Boundary Layer, Heat Transfer and Fluid Mechanics Institute, University of California at Berkeley, June 1958.

VII. Theory of Turbulence

G. K. BATCHELOR, *The Theory of Homogeneous Turbulence*, Cambridge University Press, 1953.

G. K. BATCHELOR and A. A. TOWNSEND, Turbulent Diffusion, *Survey in Mechanics*, Cambridge University Press, 1956.

J. M. BURGERS and M. MITCHNER, On Homogeneous Non-Isotropic Turbulence Connected with a Mean Motion having a Constant Velocity Gradient, *K. Neder. Akad. Wet.*, Vol. 56, pp. 228-35, 343-54, 1953.

S. CHANDRASEKHAR, On Heisenberg's Elementary Theory of Turbulence, *Proc. Roy. Soc., A*, Vol. 200, p. 20, 1949.

S. CHANDRASEKHAR, A Theory of Turbulence, *Proc. Roy. Soc., A*, Vol. 229, pp. 1-9, 1955.

S. CHANDRASEKHAR, Theory of Turbulence, *Phys. Rev.*, Vol. 102, p. 941, 1956.

S. CHANDRASEKHAR, *Convective Instability*, Daedalus, Stockholm 1957.

F. CLAUSER, Behaviour of Nonlinear Systems, *J. Aero. Sci.*, Vol. 23, No. 5, pp. 411-434, 1956.

A. CRAYA, *C. R. Acad. Sci., Paris*, Vol. 244, pp. 560, 847, 1448, 1969 (1957).

D. W. DUNN and W. H. REID, Heat Transfer in Isotropic Turbulence During the Final Period of Decay, NACA Technical Note, No. 4186, 1958.

H. W. EMMONS, The Laminar-Turbulent Transition in a Boundary Layer, *J. Aero. Sci.*, Vol. 18, p. 490, 1951.

W. HEISENBERG, Zur Statistischen Theorie der Turbulenz, *Z. Phys.*, Vol. 124, p. 628, 1948.

J. KAMPÉ DE FÉRIËT, *C. R. Acad. Sci., Paris*, Vol. 227, p. 760, 1948.

T. VON KÁRMÁN and L. HOWARTH, On the Statistical Theory of Isotropic Turbulence, *Proc. Roy. Soc., A*, Vol. 164, p. 192, 1938.

T. VON KÁRMÁN and C. C. LIN, On the Concept of Similarity in the Theory of Isotropic Turbulence, *Adv. Appl. Mech.*, Vol. 2, p. 1, 1951.

A. N. KOLMOGOROFF, *Dokl. Akad. Nauk, SSSR*, Vol. 31, p. 538; Vol. 32, p. 16, 1941.

ROBERT H. KRAICHNAN, Relation of Fourth to Second Moments in Stationary Isotropic Turbulence, *Phys. Rev.*, Vol. 107, pp. 1485-90, 1957.

ROBERT H. KRAICHNAN, Irreversible Statistical Mechanics of Incompressible Hydromagnetic Turbulence, *Phys. Rev.*, Vol. 109, pp. 1407-22, 1958.

R. E. LANGER, The Asymptotic solutions of a Class of Ordinary Differential Equations of the Fourth Order, With Special Reference to an Equation of Hydrodynamics, *Trans. Amer. Math. Soc.*, Vol. 84, pp. 144-91, 1957.

C. C. LIN, *The Theory of Hydrodynamic Stability*, Cambridge University Press, 1955.

C. C. LIN, On the Instability of Laminar Flow and its Transition to Turbulence. Presented at the Symposium on Boundary Layer Theory, Freiburg, Germany 1957 (to appear in the *Proceedings*).

J. LAUFER, On the Oscillations in the Supersonic Boundary Layer. Presented at the 9th International Congress of Applied Mechanics, 1956 (to appear in the *Proceedings*).

- W. V. R. MALKUS, Outline of a Theory of Turbulent Shear Flow, *J. Fluid Mech.*, Vol. 1, pp. 521-39, 1956.
- D. MEKSYN and J. T. STUART, Stability of Viscous Motion Between Parallel Planes for Finite Disturbances, *Proc. Roy. Soc., A*, Vol. 208, p. 517, 1951.
- M. MILLIONSHCHIKOV, *Dokl. Akad. Nauk, SSSR*, Vol. 22, pp. 231, 235, 1939; Vol. 32, pp. 615, 619, 1941.
- A. M. OBUKHOFF, *Dokl. Akad. Nauk, SSSR*, Vol. 32, p. 19, 1941.
- L. ONSAGER, The Distribution of Energy in Turbulence (abstract only), *Phys. Rev.*, Vol. 68, p. 286, 1945.
- I. PROUDMAN and W. H. REID, On the Decay of a Normally Distributed and Homogeneous Turbulence Field, *Phil. Trans. Roy. Soc., A*, Vol. 247, p. 163, 1954.
- F. B. REIS, Studies of Correlation and Spectra in Homogeneous Turbulence, Ph.D. Thesis, M.I.T., 1952.
- G. B. SCHUBAUER, Boundary Layer Transition, paper presented at the Freiburg Symposium, 1957.
- G. B. SCHUBAUER and P. S. KLEBENOFF, Contributions to the Mechanics of Boundary Layer Transition, NACA TN 3489, 1955.
- J. T. STUART, On the Non-linear Theory of Hydrodynamic Stability, *J. Fluid Mech.*, May 1958.
- T. TATSUMI, *Proc. Roy. Soc., A*, Vol. 239, pp. 16-45, 1957.
- SIR GEOFFREY TAYLOR, Statistical Theory of Turbulence. *Proc. Roy. Soc.*, Vol. 181, p. 421, 1935.
- SIR GEOFFREY TAYLOR, *Proc. Roy. Soc., A*, Vol. 164, p. 476, 1938.
- A. A. TOWNSEND, *The Structure of Turbulent Shear Flow*, Cambridge University Press, 1956.
- W. WASOW, Asymptotic Solution of the Differential Equation of Hydrodynamic Stability in a Domain Containing a Transition Point, *Ann. Math.*, Vol. 58, pp. 222-52, 1953.
- C. F. VON WEISZÄCKER, Das Spektrum der Turbulenz bei grossen Reynodsschen Zahlen, *Z. Physik*, Vol. 124, p. 614, 1948.